

Ku-Band Solid-State Power Amplifier

This high power solid-state amplifier offers an output power of 200 watts across the standard 14.0 to 14.5 GHz satellite uplink band. Built for reliable, trouble-free service, the amplifier incorporates a microprocessor-based monitor and control systems.

Features

- 200 W saturated output power
- 75 dB minimum gain
- Gain adjustment (remote controllable)
- Direct-reading RF power meter
- Microprocessor-based monitor and control
- Serial interface (RS232/422/485) standard
- Dual power supplies with soft-fail
- Output isolator for high VSWR protection

Options

- Front panel RF In/Out sample ports
- Parallel I/O with Form 'C' outputs and optoisolated inputs
- Built-in 1:1 redundancy control — no external controller required
- 48 Vdc prime power



Functional Description

This rugged, reliable, solid-state power amplifier delivers the power output of a TWTA yet achieves lower intermodulation distortion and longer lifetime than tube type amplifiers.

VertexRSI has incorporated a number of features into its in-house all GaAs FET SSPA modules, including low loss power combining techniques, active bias regulation for stable Q-point vs. time and temperature, microprocessor-based current fault monitoring of each RF power module, and low dropout dc regulation to minimize wasted power.

The amplifier incorporates complete thermal management, optimized by thermal analysis CAD software to deliver lower device junction temperatures. The forced-air cooling system draws cool air in through front panel vents and exhausts air out the rear panel vents.

This model uses high efficiency switching power supplies. Dual supplies operate independent halves of the amplifier in a soft-fail configuration; if one supply fails, the SSPA will continue to operate at 6 dB down from full power. The dc power, regulation, and bias circuitry are all optimized to minimize generation of waste heat.

Remote Control

The standard unit contains one Form 'A' summary fault output and serial I/O to allow control and monitoring of the SSPA from a remote location. The 9-pin serial interface can be connected to RS-232 unbalanced, RS-422 balanced, or RS-485 multidrop interfaces. Baud rates are selectable from 1200, 2400, 4800, 9600, or 19200 baud. Unit addresses can be set between 0 and 255. Features controlled and monitored remotely include:

FAULTS

- List faults
- Reset faults

OPERATE

- Operate/Mute
- Gain
- Antenna/Dummy Load (1:1 systems with System Option 2)

1:1 (with Option 4)

- Auto/Manual Mode
- On-Line/Standby
- Status

SERVICE

- Metering
 - Power Output
 - Temperature
 - Current
 - Voltage
- μ P Test

SETUP

- Faults
- Power Cal
- Serial I/O
- Power-up State
- Password

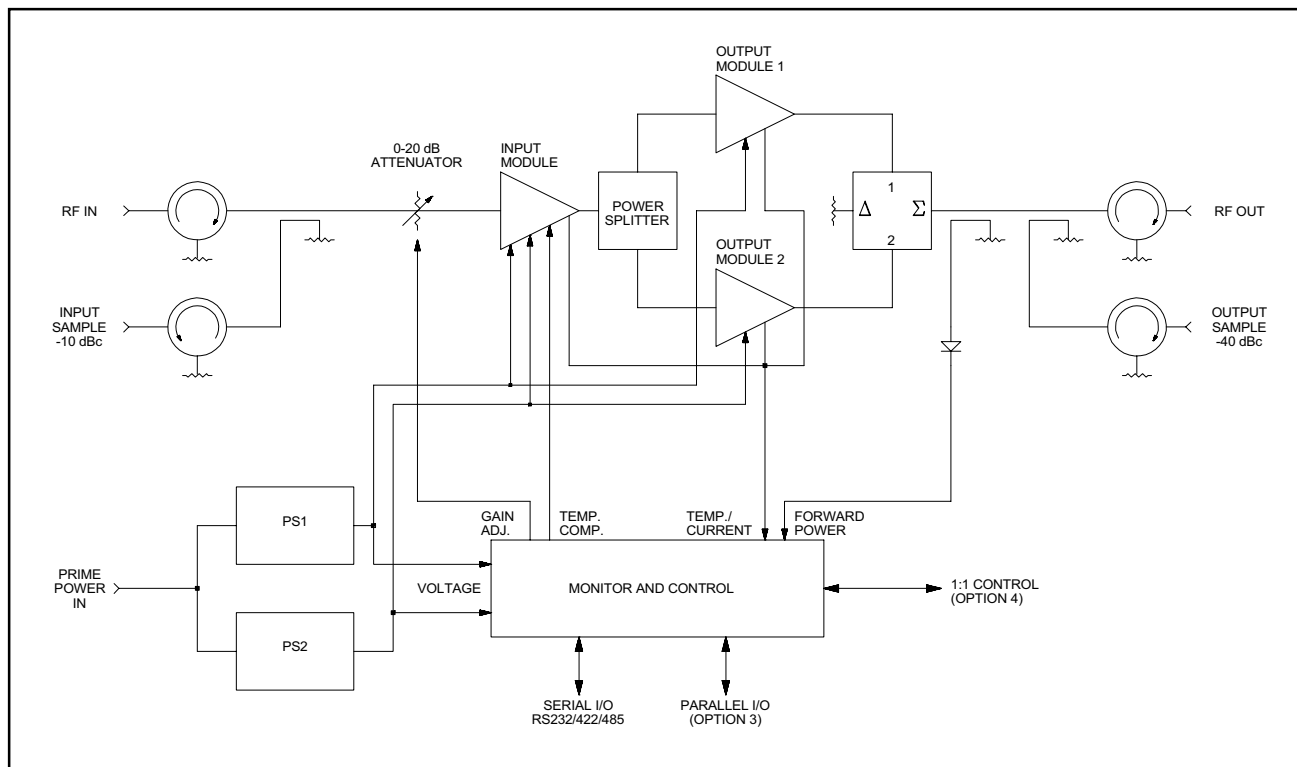

Operator Interface

Microprocessor-based monitor and control simplifies amplifier operation and allows incorporation of powerful user-friendly features, such as direct-reading RF power metering with display in dBm, dBW, or watts. Operation is menu-driven, with simple, logical

menus arranged in order of most frequent use. Four menu softkeys are used to scroll through menus and make selections, while two keys are used to increment or decrement parameters. Information is presented on an alphanumeric 2-line by 20-character backlit liquid-crystal display.

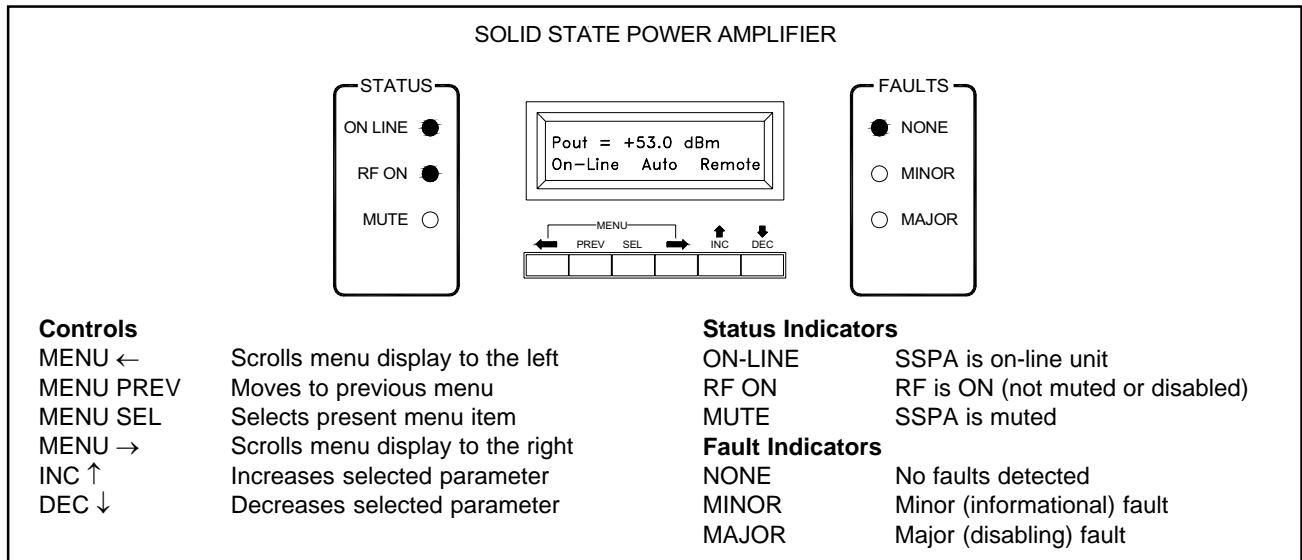

Fault Monitoring and Metering

The internal microprocessor continually monitors operation of the SSPA and reports any faults on the front panel display. Monitored parameters include microprocessor status, overtemperature shutdown, heatsink temperature, device currents, power supply voltages, RF output level, 1:1 status (with Option 4), maintenance switch position (with System Option A), and reflected power (with System Option B). Nominal

values and tolerances are all adjustable from the front panel via the setup menu. Password protection can be activated to prevent inadvertent or unauthorized access. Faults are reported as either major (disabling) or minor (informational). Major faults will cause automatic switchover in a 1:1 redundant system, but minor faults will not.

The following parameters can be displayed via the operate and service menus:

Parameter	Features/Notes	Measurement Range	Resolution
Gain Adjust		0 to -20 dB	0.1 dB
Power Output	Can be offset ± 6 dB in 0.1 dB steps for calibration/loss compensation.	+23 to +55 dBm	0.1 dB (top 20 dB)
Temperature	Heatsink	-40.0 to +85.0 °C	0.5 °C
Current	Input stages Output modules Total current	0 to 10.00 A 0 to 33.3 A 0 to 199.99 A	40 mA 120 mA 40/120 mA
Voltage	Each supply	0 to 12.50 V	50 mV
Reflected Power	Available on 1:1 systems only (with System Option B).	+23 to +55 dBm	0.1 dB (top 20 dB)

1:1 Option

This option adds 1:1 redundancy switchover logic to the SSPA. With this option, no external redundancy controller is required. The complete 1:1 redundant SSPA system consists of two SSPAs, an external switching assembly, and a cable to link the SSPAs. If a fault occurs in one of the units, it is switched off-line. Full remote control of the system is available via the serial I/O interface (or parallel I/O with Option 3).

A maintenance switch at the system output is offered as an option. This allows operation of the system into the antenna or into a dummy load. This switch is controlled and its position is monitored via the serial I/O interface.

A reflected power monitor is also available as an option. Reflected power is measured at the system's output and can be monitored via the serial I/O interface.

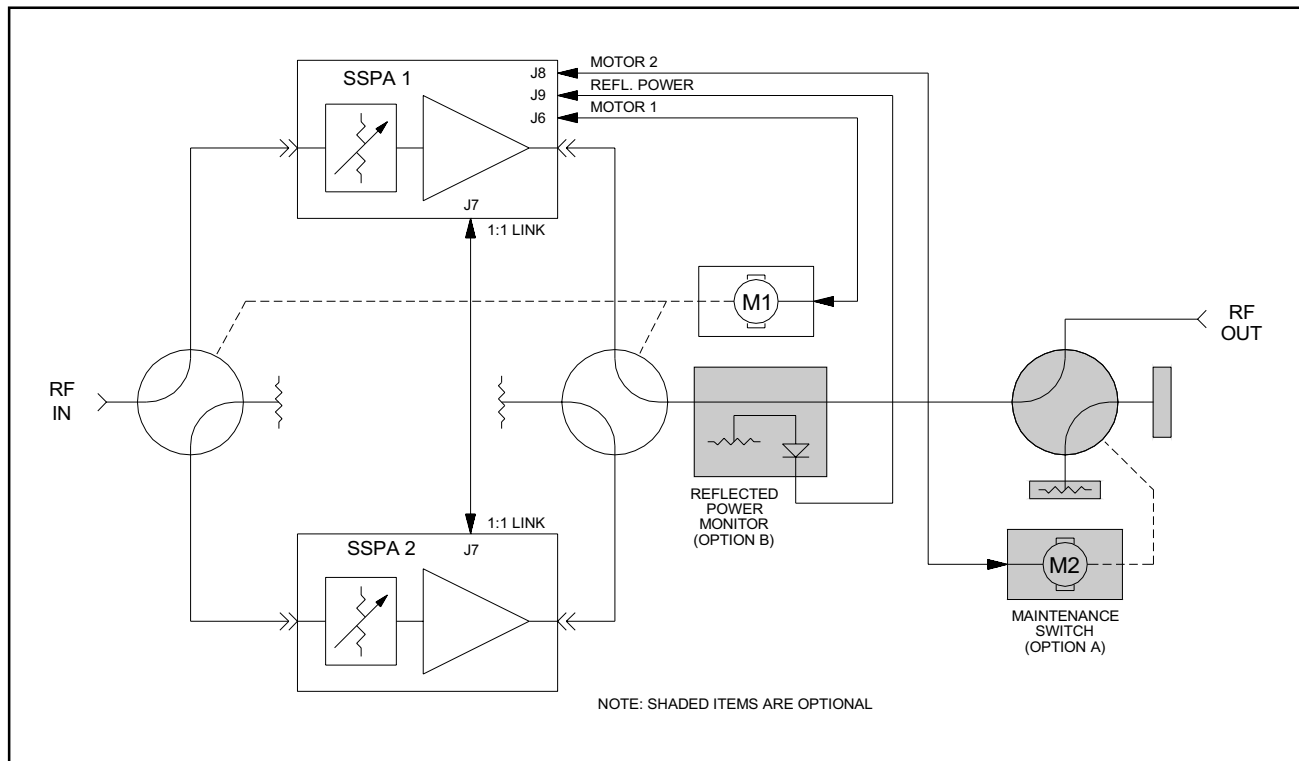

Parallel I/O Option

This option adds eight Form 'C' status outputs, and eight contact-closure-to-ground control inputs, and an analog voltage output that is proportional to forward power. Each input or output is menu selectable.

Form 'C' Status Outputs

- Major/Minor Faults
 - Mute/Unmute/RF Inhibit
 - Faults: Summary, Power Out, Reflected Power, Voltage, Current and Temperature
 - Remote, Local, Maintenance Mode
- with 1:1 Option*
- Auto/Manual
 - On-Line/Standby
 - Antenna/Dummy Load Position

Control Inputs

- Major/Minor Faults
 - Mute/Unmute/RF Inhibit
 - Fault Reset
- with 1:1 Option*
- Auto/Manual Select
 - Standby/On-Line
 - Antenna/Dummy Load

Analog Output

- Proportional to forward power, 0 to 5 Vdc nominal, 0.1 V/dB (5 V = +50 dBm)
- Balanced, 2-wire. Can be run over long distances.
- Drives loads to 600 ohms min.

SPECIFICATIONS

PKM14S200R-XX

Parameter	Notes	Min	Nom/Typt†	Max	Units
Frequency Range		14.0		14.5	GHz
Gain	At maximum gain setting	75			dB
Gain Adjust Range		20			dB
Gain Flatness	Full band			±1.0	dB
	Per 40 MHz			±0.3	dB
Power Output	Saturated		+53 (200)		dBm (W)
	At 1 dB compression	+52 (160)			dBm (W)
Two-tone Intermodulation At 3 dB total backoff	+49 dBm out		-30	-25	dBc
Residual Noise	13.75-14.50 GHz			-70	dBW/4 kHz
	1.00-12.75 GHz			-130	dBW/4 kHz
Group Delay per 40 MHz Band Segment	Linear			0.03	ns/MHz
	Parabolic			0.003	ns/MHz ²
	Ripple			1.0	ns p-p
AM/PM Conversion	At P _{1dB}		2.5	3.0	°/dB
VSWR	Input		1.20	1.25	:1
	Output		1.20	1.30	:1
Front Panel Sample Ports (Optional)	Input		-10		dBc
	Output		-40		dBc
Connectors	Input		SMA Female		
	Output		WR75G Waveguide		
	Sample Ports (Optional)		Type N Female		
	Serial I/O		9-pin D, Female		
	Parallel I/O (Optional)		37-pin D, Male		
	Power		3-pin MS, Male		
Power Requirements (Single Phase)	Voltage	180		264	Vac
	Frequency	47		63	Hz
	Power Factor		0.98		
	Power		2.2	2.4	kW
Cooling System		Forced air. Intake on front panel.			
Operating Temperature Range	Ambient air temperature	0		+50	°C
Dimensions and Weight		19 W x 15.75 H x 26 D 483 W x 400 H x 660 D 190 (86)			inches mm lb (kg)

† When there is only one value on a line, this column is a nominal value. Otherwise it is a typical value. Typical values are intended to illustrate typical performance, but are not guaranteed.

Outline Drawing, SSPA

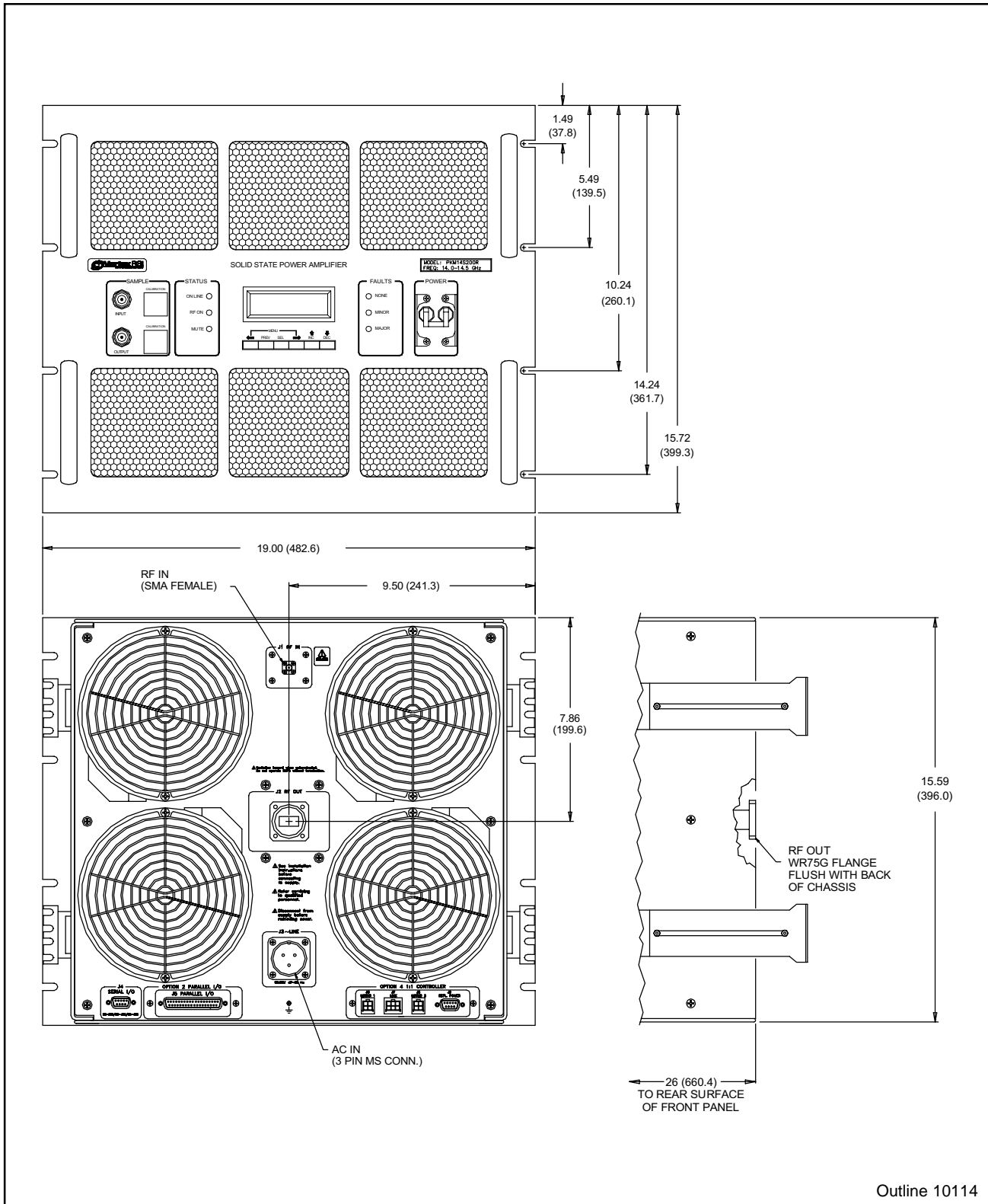

Outline 10114

Outline Drawing, 1:1 System

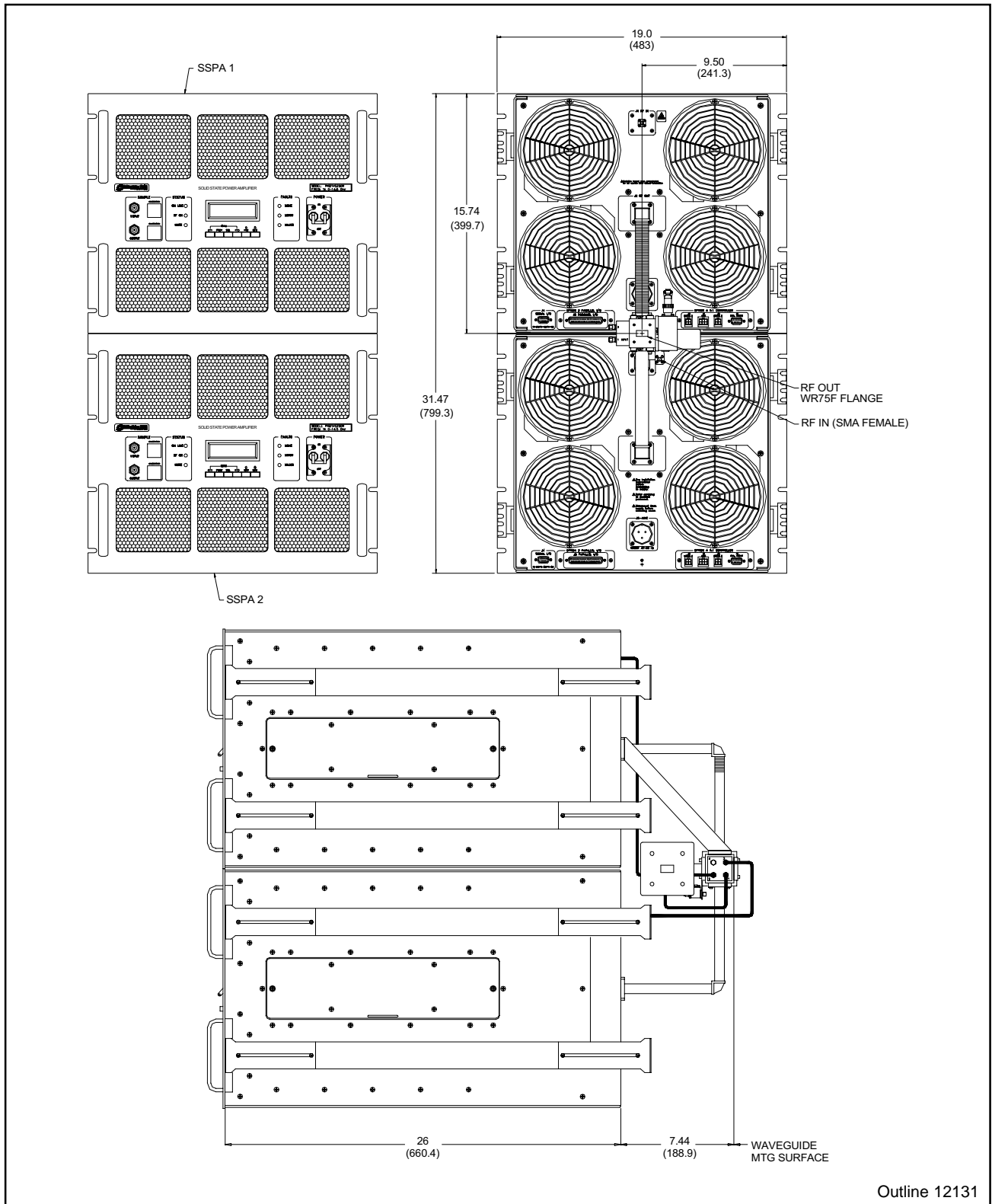

Outline 12131

Connector Interface

Ref. Des.	Function	Connector Type	Mating Connector	Comment
J1	RF Input	Type N Female	Type N Male	
J2	RF Output	WR75G Waveguide	WR75 Flange	
J3	AC In	3-pin MS, Male	3-Pin MS, Female	Supplied
"	DC In	4-pin MS, Male	4-pin MS, Female	Option 6
J4	Serial I/O	9-pin D, Female	9-pin D, Male	Standard
J5	Parallel I/O	37-pin D, Male	37-pin D, Female	Option 3
J6	1:1 Switch	4-pin Molex	4-pin Molex	Option 4
J7	1:1 Link	6-pin Molex	6-pin Molex	Option 4

Part Number/Ordering Information

SSPAs:

PKM14S200R-XX

Options: Parallel I/O 3

Form 'C' status outputs (100 Vdc/0.5 A contacts) and contact closure to ground (5 V/5 mA) control inputs.

1:1 Redundancy 4

Redundant capability (required for units in 1:1 systems)

Redundant Systems:

(Consists of 1:1 switching assembly, two SSPAs, and interconnecting cables.)

PRK1M200R-XXX

Options: Parallel I/O 3

Form 'C' status outputs (100 Vdc/0.5 A contacts) and contact closure to ground (5 V/5 mA) control inputs.

Maintenance Switch A

Allows selection of antenna or dummy load at system output

Reflected Power Monitor B

Measures reflected power at system output

Related Accessories:

- **RCP-1000** SSPA Remote Control Panel
1U-high rack-mounted panel duplicates all menus and functions available at SSPA front panel. Can be located up to 1.3 km (4000 ft) away and interconnects with inexpensive cable.
- **MAXCON™** Monitor and Control Software. Microsoft® Windows® application.



13215 Rev. A 12/10/03

Specifications are subject to change at VertexRSI's discretion.