

# 123T Antenna Control System

*Simplified transportable satellite tracking*

## Key Features

- Optrack, Steptrack and Pointing Modes
- LCD display with full alphanumeric readouts
- Simplified Operation
- GPS, Flux Gate Compass, Inclinometer interface
- L, S, C, X, Ku, Ka band operation including Multi-Band
- Multiple Antenna Support

## Options

- Hand Held Jog Controller (PMU)
- Internal L-Band or 70 MHz tracking receiver (redundant receiver available)
- External Model 253 tracking receiver with integral block down converters
- Ethernet, RS422, or RS232 supervisory computer interface



## Key Features

The Model 123T provides precision satellite tracking with most Mobile, Transportable, or Flyaway Antennas.

The Antenna Control Unit (ACU) is the operator interface point for the system, featuring PC-104 based processing and operator-friendly function menus. The Power Drive Unit (PDU) provides all motor and antenna connections.

## Internal Tracking Receiver Options

The Model 250 receiver is available with L-Band or 70 MHz input. L-Band frequency range is 950-2150 MHz and the tracking C/NO is 40 dB-Hz. Dual Model 250 receivers can be installed for redundancy.

## Antenna Pointing Accuracy

Normally better than 0.07° RMS (0.05° optional) in winds of 30 mph gusting to 45 mph. Includes all drive train errors but excludes structural errors between the transducers and RF beam.

## Tracking Accuracy - Optrack

Optrack provides high performance tracking of stable or inclined orbit satellites with an adaptive self-learning ephemeris modeling mode. The Control System accuracy (excluding non-repeatable mechanical errors) is normally better than 5% RMS (0.03 dB) of the receive beamwidth in winds of 30 mph gusting to 45 mph, satellite inclination of up to 15° and signal scintillation of up to 2 dB.

A variety of operational modes are available for quick target acquisition, pointing and tracking.

Operational Modes			
Tracking	Pointing	Acquisition	Other
Optrack	Intelsat	Smart Scan	Maintenance
Steptrack	NORAD*		Standby
	Preset Position		Deploy
	Manual Jog		Stow
	Eutelsat*		Calibrate
* Optional			

## PROVEN PERFORMANCE / EXPERIENCE

Antenna	Band	Testing
240 MVO/DMVO (VRSI)	QUAD	DISA, Intelsat
2.4 SM-LT (VRSI)	QUAD	DISA, Intelsat
8' GMF	X	Engineering
3.8M VRSI (VRSI)	TRI	DISA, Intelsat
2.4M Flyaway (SF-LT) (VRSI)	TRI	DISA, Intelsat
2.4M High Wind (HWT) (VRSI)	QUAD	DISA, Intelsat
4.6M DMVO (VRSI)	TRI	Engineering
2.1M TMS305	X	NATO
LHGXA	X	DISA
QRSA	X	DISA

## REMOTE GRAPHICAL USER INTERFACE OPTION

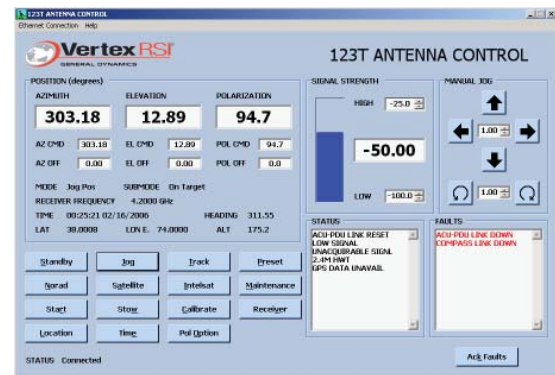

## 123T System Diagram

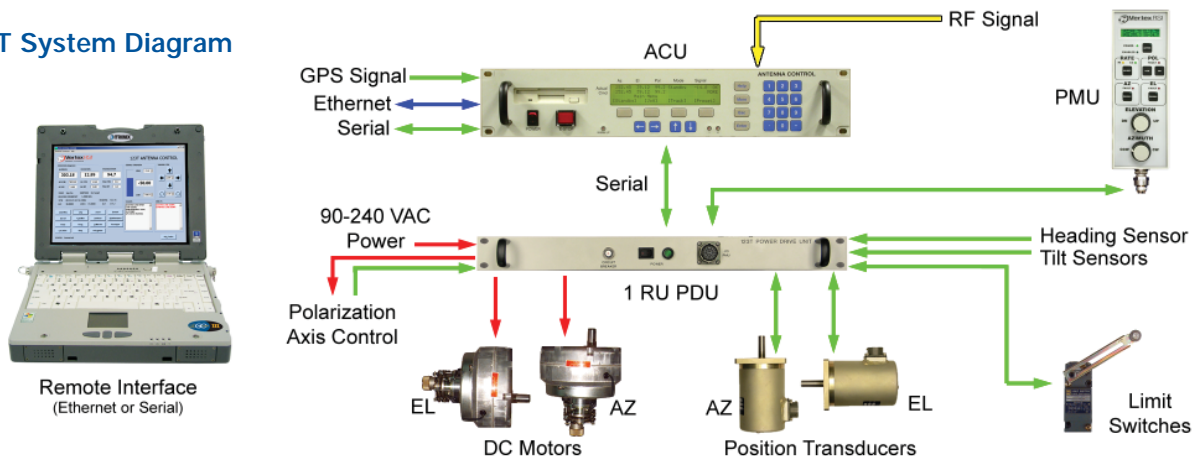

## SPECIFICATIONS

- CE Certified
- Passed Munsen Road Test (shock and vibration)
- Passed DISA Tracking Stability Test
- Auto Calibrate, Auto Deploy, Auto Stow
- Single RS 222 Cable for ACU to PDU link
- EL current detect circuit used during stow to produce known antenna "clamp down" torque

ACU	Size	Weight	Power
2RU rack mount chassis with sides	3.5" H x 19" W x 16.38" D	16 lbs	Accepts 120/230 VAC, 50/60 Hz, 60W
PDU			
2RU rack mount chassis with slides	3.5" H x 19" W x 17.13" D	21 lbs.	Accepts 120/230 VAC, 50/60 Hz, 800W Peak
1RU rack mount chassis with slides	1.75" H x 19" W x 17.13" D	18 lbs	Accepts 120/230 VAC, 50/60 Hz, 800W Peak
Antenna Interface			
AZ/EL/POL DC Motor amplifiers available for 24 -36V motors. Potentiometer or Resolver Position Feedback supported.			
EL velocity limit and AZ centered switch inputs available.			
Environmental		Temperature	Humidity
Operating		-20° to 60° C	95% Non-Condensing
Storage		-40° to 70° C	95% Non-Condensing

## GENERAL DYNAMICS

SATCOM Technologies • 1219 Digital Drive • Richardson, Texas 75081  
 Tel: 972-907-9599 • Fax: 972-907-0027 • www.gdc4s.com • www.gdsatcom.com

© 2006 General Dynamics. All rights reserved. General Dynamics reserves the right to make changes in its products and specifications at any time and without notice.  
 GD-SatcomTech-002 Feb 2006